

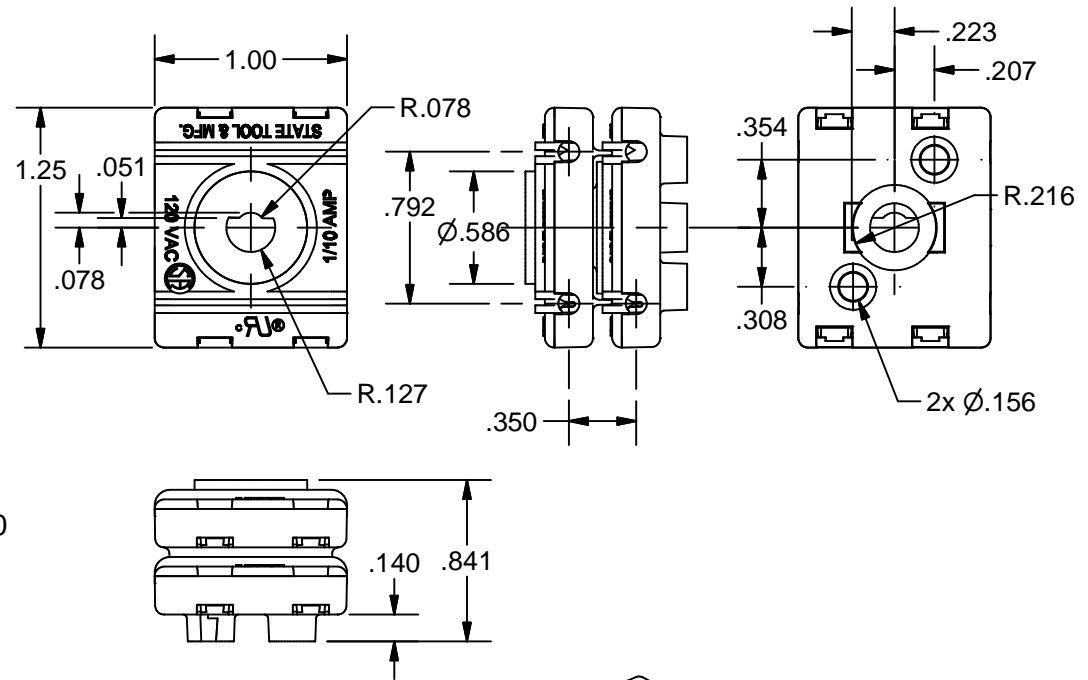

Specifications:

- 1) Switches are used on BSI Aluminum Mini Valves and mount on valve stem crown and two screw heads.
- 2) Electrical Rating: .10 amp 120 VAC 60 Hz
- 3) Actuator Rotation: counter-clockwise
- 4) ON/OFF Rotation Range: Custom designed to match customer requirements
- 5) Wire: 20 ga. stranded
- 6) UL Recognized: Special Use Switch Standard UL1054, File No. 85183, UL Guide No. WOYR2
- 7) CSA Approved: File No. LR-41020-29, CSA Guide No. 6241-10
- 8) Insulation displacement type.
- 9) Typ. mounting for: 35520-1; -2;



Test Data:

- 1) Life Cycle Test: 30,000 cycles min. ON/OFF (UL requires 6,000 cycles min.)
- 2) Heat Test: Switch materials to withstand 300°F / 150° C min. without loss of function.
- 3) Power Factor Test: Watts / Voltage x Amps = Between .75 and .80
- 4) Overload Test: 150 ma (150%) for minimum of 50 cycles.
- 5) Contact Resistance: .5 ohms max. after 6,000 cycles.
- 6) Contact Heat Rise: 30° C max. above ambient temperature.
- 7) Insulation Resistance (mounted): Between valve and ground is 20 mega ohms min.
- 8) Post test Hypot: Withstand 1000 volts (1 min. duration) at end of 30,000 cycles. (UL requires 6,000 cycles min.)
- 9) Wire Retention: Withstand 8 lbs. min. pull-out force.
- 10) Mounting Integrity: Push-on force 14 lbs. max. Pull-off 5 lbs. min.
- 11) Switch Assembly Drop Test: Withstand 3 meter fall to cement surface without damage.

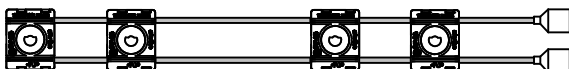
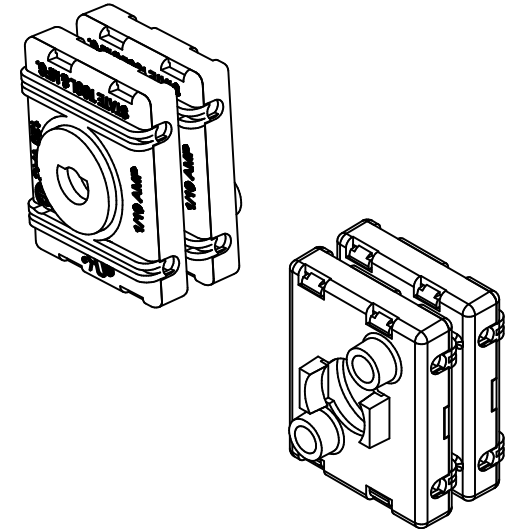

AVAILABLE IN CUSTOM HARNESS FORM ONLY